

PUNCH AND DIE DIMENSION WORKSHEET

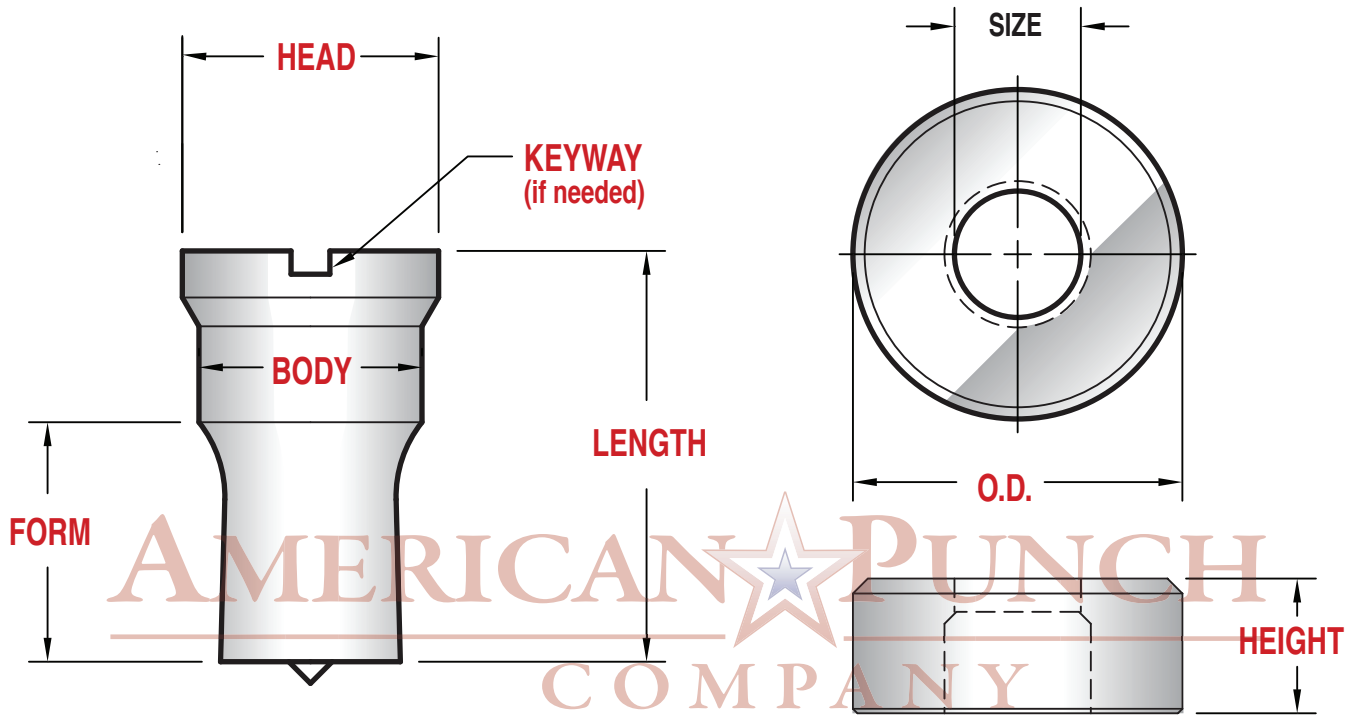

Please provide the following dimensions:

HEAD:

BODY:

FORM:

LENGTH:

KEYWAY: X

WIDE DEEP

Please provide the following dimensions:

O.D.:

HEIGHT:



www.AmericanPunchCo.com • sales@AmericanPunchCo.com

800.243.1492

